

GRANISMART 2 TS-E 230/50 WHITE
 GRANISMART 2 TS-E 230/50 WHITE UK
 GRANISMART 2 TS-E 230/50 WHITE AUST

V02
 V02
 V02

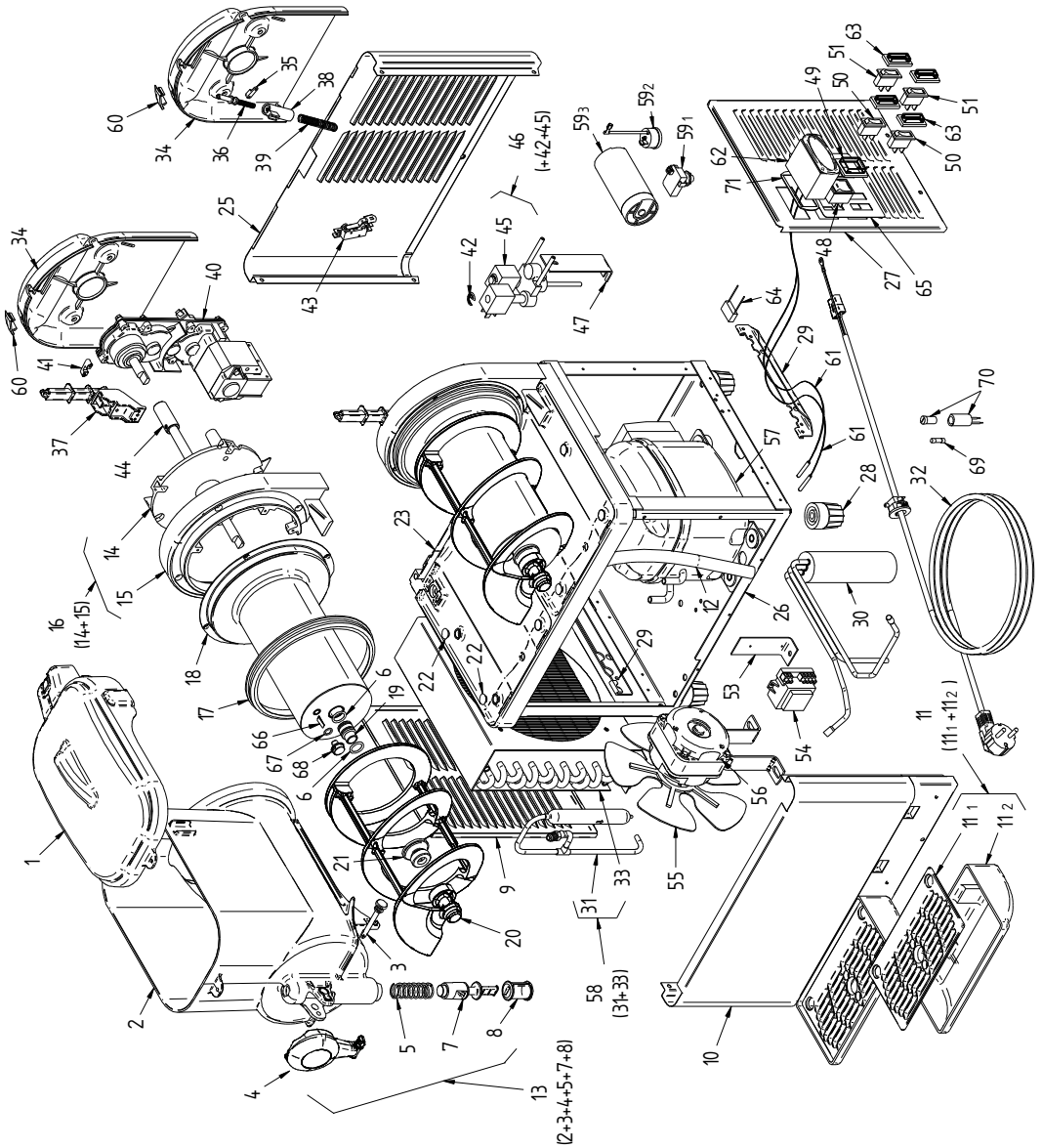

SL310003841 Ed06 - 12/2015

GRANISMART 2 TS-E 230/50 WHITE & UK & AUST

1	SL320000815	Tapa depósito GS - blanca	Bowl cover GS - white	Coperchio vasca GS - bianco
2	SL340000541	Depósito GS + Adhesivo	Bowl GS + Adhesive	Vasca GS + Adesivo
3	SL300951293	Pasador leva grifo - blanco	Tap lever fastener - white	Perno leva rubinetto - bianco
4	SL340001687	Leva grifo - blanca + Adhesivo	Dispensing lever - white + Adhesive	Leva rubinetto - blanca + Adesivo
5	SL320001401	Muelle grifo	Tap spring	Molla rubinetto
6	SL310001843	Junta tórica Ø15 x Ø2 sil. alim. - roja	O-Ring Ø15 x Ø2 silicon - red	Guarnizione Ø15 x Ø2 sil. alim. - rossa
7	SL320001629	Pistón grifo LD ETL - blanco	Tap plunger LD ETL - white	Pistone rubinetto LD ETL - bianco
8	SL320001759	Junta especial pistón LD - blanca	Tap plug LD - white	Guarnizione rubinetto LD - blanca
9	SL320000840	Panel lateral izquierdo	Left side panel	Pannello laterale sinistro
10	SL320000884	Panel frontal GS	Front panel GS	Pannello anteriore GS
11	SL340000501	Bandeja + Rejilla goteo GB - blanca	Dripping Tray + Grating GB - white	Vaschetta + Griglia scarico GB - bianca
11.1	SL300970007	Rejilla goteo GB - blanca	Dripping grating GB - white	Griglia scarico GB - bianca
11.2	SL300970003	Bandeja goteo GB - blanca	Dripping tray GB - white	Vaschetta scarico GB - blanca
12	SL30PZ12NT8	Tubo desagüe silicona 8x12 x mts	Drain pipe silicon 8x12 x mts	Tubo scarico silicone 8x12 x mts.
13	SL310007440	Depósito completo GS - blanco	Bowl set GS - white	Vasca completa GS - bianca
14	SL320000788	Soporte evaporador PZ.2 - blanco	Evaporator support PZ.2 - white	Supporto evaporatore PZ.2 - bianco
15	SL300951868	Soporte evaporador PZ.1 - blanco	Evaporator support PZ.1 - white	Supporto evaporatore PZ.1 - bianco
16	SL310003258	Soporte evaporador completo PZ.1 + PZ.2 - blanco	Evaporator support set PZ.1 + PZ.2 - white	Supporto evaporatore completo PZ.1 + PZ.2 - bianco
17	SL300500133	Junta depósito - roja	Tank joint - red	Guarnizione evaporatore - rossa
18	SL340001668	Evaporador	Evaporator	Evaporatore
19	SL320002598	Casquillo estanqueidad evaporador	Evaporator watertight gasket	Boccola tenuta evaporatore
20	SL320000795	Pala espiral	Spiral shovel	Coclea
21	SL310003630	Junta estanqueidad eje sil.translu.	Watertight shaft joint sil.translu.	Guarnizione tenuta albero sil.translu.
22	SL300950069	Tapón bandeja superior - blanco	Upper tray cap - white	Tappo piano evaporatore - bianco
23	SL320000793	Bandeja superior - blanca	Upper tray - white	Piano evaporatore - bianco
24				
25	SL320000810	Panel trasero	Rear panel	Pannello posteriore
26	SL320000773	Chasis	Chassis	Telaio
27	SL310000819	Panel lateral derecho + Adhesivo	Right side panel + Adhesive	Pannello laterale destro + Adesivo
28	SL300951357	Pie nivelador	Leveling foot	Piede livellatore
29	SL320000812	Soporte panel lateral	Side panel support	Supporto pannello laterale
30	SL340000487	Expansorador	Boiler	Boiler

GRANISMART 2 TS-E 230/50 WHITE & UK & AUST

55	SL330000171	Hélice ventilador Ø 200 x 34°	Elica ventilatore Ø 200 x 34°
56	SL330000213	Motovelentador 10 W 220/60	Motovelentatore 10W 220/60
57	SL310002672	Compresor	Compresore
58	SL340000513	Condensador + Filtro	Condensatore + Filtro
59 1	SL310002663	Relé compresor	Relé compresore
59 2	SL310002854	Clixon compresor	Salvavolante compresore
59 3	SL310002985	Condensador arranque compresor	Condensatore compresore
60	SL300951191	Obturador tapa soporte evaporador - blanco	Tappo coperchio supporto evaporatore - bianco
61	SL310007282	Sonda temperatura	Sonda temperatura
62	SL330000424	Visualizador electrónico	Visualizzatore di temperatura
63	SL330000119	Protector interruptor 11x30	Protezione interruttore 11x30
64	SL310002832	Condensador 0,022 uF	Condensatore 0,022 uF
65	SL310002630	Adhesivo panel mandos	Adesivo pannello portacomandi
66	SL310005968	Sujeción sonda interna frontal	Fermo sonda interna anteriore
67	IC541000418	Junta tónica 1,78x11,11 SL 60 114 roja	Guarnizione 1,78x11,11 SL 60 114 rossa
68	SL310005969	Tapón sonda interna evap. (PLAST.)	Tappo sonda interna evap. (PLAST)
69	SL310002973	Fusible 32 mA.	Fusibile 32 mA.
70	SL300901135	Portafusible	Porta fusibile
71	SL320002695	Junta estanqueidad TS-E	Guarnizione tenuta TS-E

GRANISMART 3 TS-E 230/50 WHITE
GRANISMART 3 TS-E 230/50 WHITE UK
GRANISMART 3 TS-E 230/50 WHITE AUST

V02
V02
V02

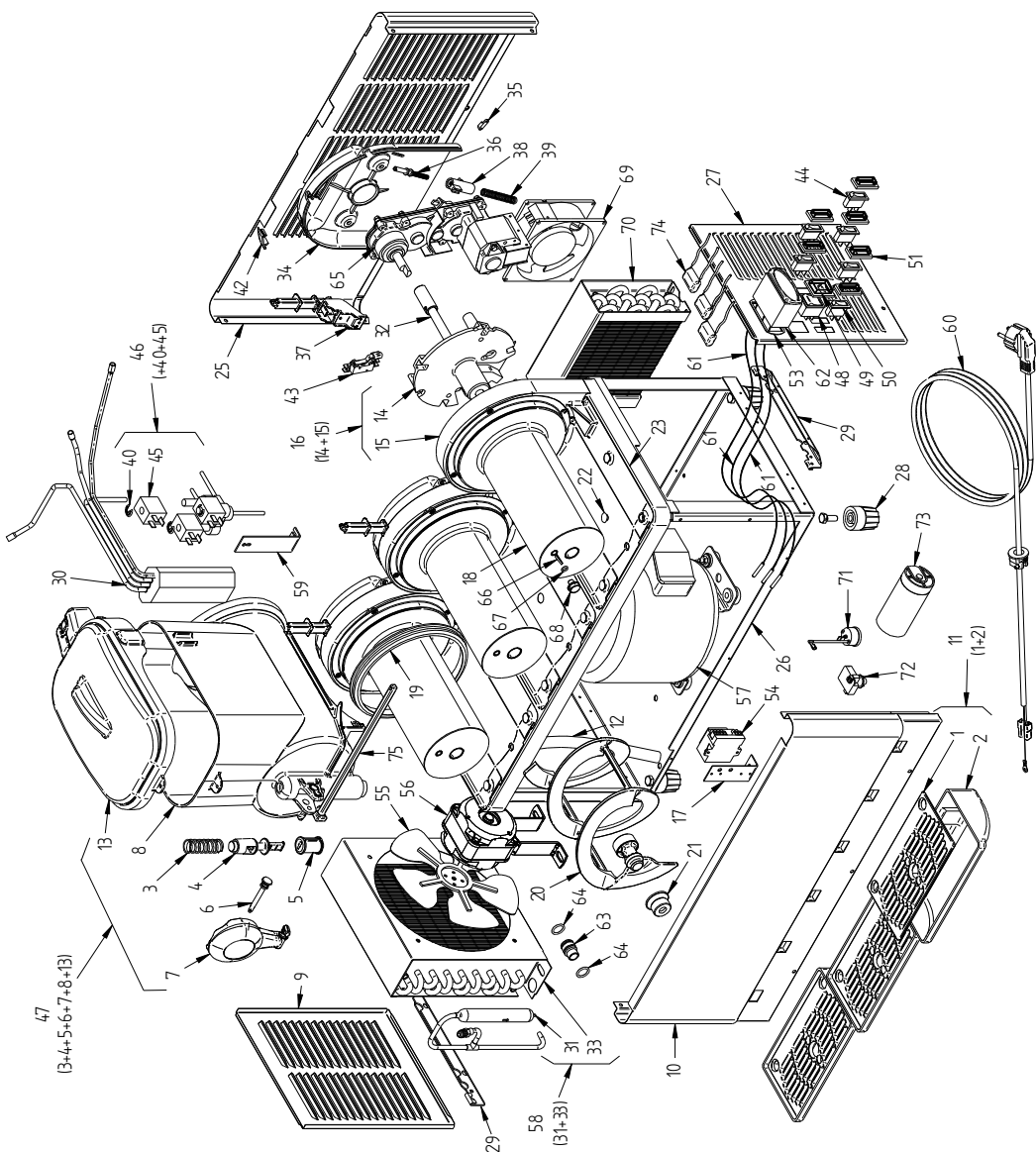

GRANISMART 3 TS-E 230/50 WHITE & UK & AUST

1	SL300970007	Rejilla goteo GB - blanca	Dripping grating GB - white	Griglia scarico GB - bianca
2	SL300970003	Bandeja goteo GB - blanca	Dripping tray GB - white	Vaschetta scarico GB - blanca
3	SL320001401	Muelle grifo	Tap spring	Molla rubinetto
4	SL320001629	Pistón grifo LD ETL - blanco	Tap plunger LD ETL - white	Pistone rubinetto LD ETL - bianco
5	SL320001759	Junta especial pistón LD	Tap plug LD	Guarnición rubinetto LD
6	SL300951293	Pasador leva grifo - blanco	Tap lever fastener - white	Perno leva rubinetto - blanco
7	SL340001687	Leva grifo - blanca - Adhesivo	Dispensing lever - white - Adhesive	Leva rubinetto - blanca + Adesivo
8	SL340000541	Depósito GS + Adhesivo	Bowl GS + Adhesive	Vasca GS + Adesivo
9	SL320000840	Panel lateral izquierdo	Left side panel	Pannello laterale sinistro
10	SL320002626	Panel frontal GSM 3	Front panel GSM 3	Pannello anteriore GSM 3
11	SL340000501	Bandeja + Rejilla goteo GB - blanca	Dripping Tray + grating GB - white	Vaschetta + Griglia scarico GB - blanca
12	SL30PZ12NT8	Tubo desagüe silicona 8x12 x mts	Drain pipe silicon 8x12 x mts	Tubo scarico silicone 8x12 x mts.
13	SL320000815	Tapa depósito GS - blanca	Bowl cover GS - white	Coperchio vasca GS - bianco
14	SL320000788	Soporte evaporador PZ.2 - blanco	Evaporator support PZ.2 - white	Supporto evaporatore PZ.2 - bianco
15	SL300951868	Soporte evaporador PZ.1 - blanco	Evaporator support PZ.1 - white	Supporto evaporatore PZ.1 - bianco
16	SL310003258	Soporte evaporador completo PZ.1 + PZ.2 - blanco	Evaporator support set PZ.1 + PZ.2 - white	Supporto evaporatore completo PZ.1 + PZ.2 - bianco
17	SL300350023	Soporte transformador	Transformer support	Supporto trasformatore
18	SL340001669	Evaporador	Evaporator	Evaporatore
19	SL300500133	Junta depósito - roja	Tank joint - red	Guarnición evaporatore - rossa
20	SL320000795	Pala espiral	Spiral shovel	Coclea
21	SL310003630	Junta estanqueidad eje sil.translu.	Watertight shaft joint sil.translu.	Guarnizione tenuta albero sil.translu.
22	SL300950069	Tapón bandeja superior - blanco	Upper tray cap - white	Tappo piano evaporatore - bianco
23	SL320001140	Bandeja superior - blanca	Upper tray - white	Piano evaporatore - bianco
24				
25	SL320002632	Panel trasero	Rear panel	Pannello posteriore
26	SL320002624	Chassis	Chassis	Telaio
27	SL320002633	Panel lateral derecho	Right side panel	Pannello laterale destro
28	SL300951357	Pie nivelador	Leveling foot	Piede livellatore
29	SL320000812	Soporte panel lateral	Side panel support	Supporto pannello laterale
30	SL310003797	Expansionador	Boiler	Boiler
31	SL310011017	Filtro	Filter	Filtro
32	SL320002576	Eje transmisión completo	Transmission shaft set	Albero trasmissione completo
33	SL330000169	Condensador	Condenser	Condensatore

GRANISMART 3 TS-E 230/50 WHITE & UK & AUST

34	SL310004348	Tapa soporte evaporador - blanco	Evaporator support cover - white	Coperchio supporto evaporatore - bianco
35	SL3GS12036A	Sujeción sistema regulación	Regulation system subjection	Fermo sistema regolazione
36	SL3GS12035A	Vástago regulación	Regulation rod	Perno regolazione
37	SL320000805	Soporte sensor	Sensor support	Supporto sensore
38	SL3GS12037B	Guía muelle sistema regulación	Regulation system spring guide	Boccola perno regolazione durezza
39	SL320003215	Muelle regulación	Regulation spring	Molla regolazione
40	SL310000444	Grapa electroválvula B4	Electrovalve clamp B4	Morsetto elettrovalvola B4
41				
42	SL300951191	Obturador tapa soporte evaporador - blanco	Evaporator support cover plug - white	Tappo coparchio supporto evaporatore - bianco
43	SL300950587	Minirruptor	Minirruptor	Microtruttore
44	SL300000964	Interruptor - negro	Switch - black	Interruttore - nero
45	SL38EAF49GL	Bobina electroválvula gas CEME 230V 50Hz	Gas electrovalve bobbin CEME 230V 50Hz	Bobina elettrovalvola gas CEME 230V 50Hz
45	SL310005788	Bobina electroválvula gas OLAB 230V 50Hz	Gas electrovalve bobbin OLAB 230V 50Hz	Bobina elettrovalvola gas OLAB 230V 50Hz
45	SL310008839	Bobina electroválvula gas OLAB 240V 50Hz UK	Gas electrovalve bobbin OLAB 240V 50Hz UK	Bobina elettrovalvola gas OLAB 240V 50Hz UK
46	SL3GS36711B	Electroválvula triple CEME 230V 50Hz	Triple electrovalve CEME 230V 50Hz	Electrovalvola tripla CEME 230V 50Hz
46	SL310005791	Electroválvula triple OLAB 230V 50Hz	Triple electrovalve OLAB 230V 50Hz	Electrovalvola tripla OLAB 230V 50Hz
46	SL310009507	Electroválvula triple OLAB 240V 50Hz UK	Triple electrovalve OLAB 240V 50Hz UK	Electrovalvola tripla OLAB 240V 50Hz UK
47	SL310007440	Depósito completo GS - blanco	Bowl set GS - white	Vasca completa GS - bianca
48	SL300003131	Interruptor general verde	Green main switch	Interruttore generale verde
49	SL330000096	Protector interruptor 22x30	Switch protection 22x30	Protezione interruttore 22x30
50	SL300951089	Commutador negro	Switch - black	Interruttore nero
51	SL330000119	Protector interruptor 11x30	Switch protection 11x30	Protezione interruttore 11x30
52				
53	SL320002895	Junta estanqueidad TS-E	Watertight joint TS-E	Clip pannello laterale
54	SL310002739	Transformador 3W, 220-115V/12V	Transformer 3W, 220-115V/12V	Guarnizione tenuta TS-E
55	SL330000171	Helice ventilador Ø 200 x 34º	Fan motor blades Ø 200 x 34º	Transformatore 3W, 220-115V/12V
56	SL330000213	Motore ventilador 10 W, 220/60	Fan motor 10 W, 220/60	Elica ventilatore Ø 200 x 34º
57	SL37ZH02134	Compresor	Compressor	Motore ventilador 10W 220/60
58	SL310006246	Condensador + Filtro	Condenser + Filter	Compressor
59	SL320000783	Soporte electroválvula	Electrovalve support	Condensador + Filtro
60	SL310003935	Cable alimentación	Power cable	Supporto elettrovalvola
60	SL320002030	Cable alimentación UK	Power cable UK	Cavo alimentazione

GRANISMART 3 TS-E 230/50 WHITE & UK & AUST

60	SI310006176	Cable alimentación AUST	Power cable AUST
61	SI310007282	Sonda temperatura	Temperatura probe
62	SI310007309	Visualizador electrónico	Electronic temperature visual display
63	SI320002598	Casquillo estanqueidad evaporador	Evaporator waerlight gasket
64	SI310001843	Junta tónica Ø15 x Ø2 sil. alm. - roja	O-Ring Ø15 x Ø2 silicon - red
65	SI330000338	Motorreductora ELCO mono 230/50	Gear motor ELCO mono 230/50
65	SI310001422	Motorreductora KENTA mono 230/50	Motoriduttore KENTA mono 230/50
65	SI310005299	Motorreductora VERNIS mono 230/50	Motoriduttore VERNIS mono 230/50
66	SI310005968	Sujeción sonda interna frontal	Internal front probe subjection
67	IC541000418	Junta tónica 1,78x11,11 SL 60 114 roja	O-ring 1.78x11,11 SL 60 114 red
68	SI310005969	Tapon sonda interna evap. (PLAST.)	Evaporator internal probe plug (PLAST.)
69	SI330000173	Motovelocidad 127x4127x38 230/50	Fan motor 127x127x38 230/50
70	SI330000168	Condensador	Condensator
71	SI300951465	Clixon compresor	Compressor clixon
72	SI300951466	Relé compresor	Compressor relay
73	SI300951743	Condensador arranque compresor	Compressor capacitor
74	SI310002832	Condensador 0,022 uF	Capacitor 0.022 uF
75	SI300951608	Eje cierre grifo - blanco (OPCIONAL)	Tap lock rod - white (OPTIONAL)
			Albero chiusura rubinetto - bianco (OPZIONALE)

Nº	Descripción	Description	Descrizione
1	Interruptor general	General switch	Interruttore generale
2			
3			
4	Compresor	Compressor	Compressore
5	Motor ventilador	Motor ventilator	Motoventilatore
6			
7	Transformador	Transformer	Trasformatore
8			
9			
10	Interruptor palas izquierda	Left shovels switch	Interruttore coclea sinistra
11	Motor palas izquierda	Engine for left shovels	Motore coclea sinistra
12	Conmutador líquido/granizado izq.	Left liquid/iced drink switch	Deviatore bibita/granita vasca sinistra
13	Micro termostato izquierda	Left micro thermostat	Microinterruttore termostato sinistro
14	Micro regulación izquierda	Left micro regulation	Microinterruttore regolazione sinistro
15	Electroválvula izquierda	Left electrovalve	Elettrovalvola sinistra
16	Interruptor palas derecha	Right shovels switch	Interruttore coclea destra
17	Motor palas derecha	Engine for right shovels	Motore coclea destra
18	Conmutador líquido/granizado der.	Right liquid/iced drink switch	Deviatore bibita/granita vasca destra
19	Micro termostato derecha	Right micro thermostat	Microinterruttore termostato destro
20	Micro regulación derecha	Right micro regulation	Microinterruttore regolazione destro
21	Electroválvula derecha	Right electrovalve	Elettrovalvola destra
22	Visualizador electrónico	Electronic temperature visual display	Visualizzatore di temperatura
23	Fusible visualizador temp.	Electronic temp. visual display fuse	Fusibile visualizzatore di temperatura

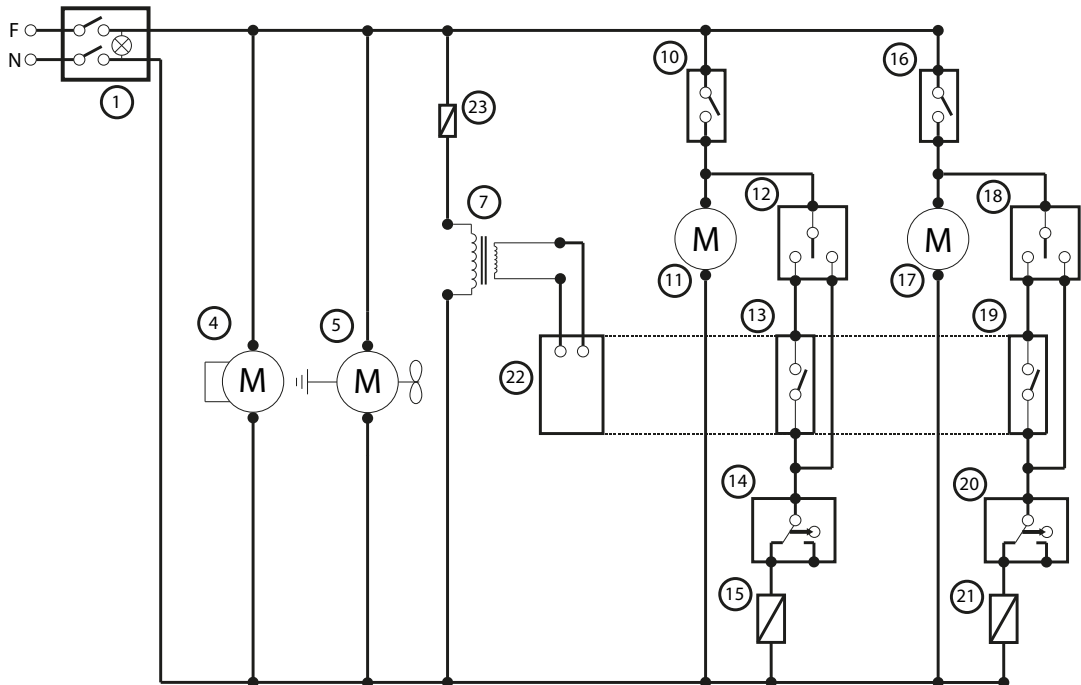

Nº	Descripción	Description	Descrizione
1	Interruptor general	General switch	Interruttore generale
2	Motor ventilador 1	Motor ventilator 1	Motovenilatore1
3	Compresor	Compressor	Compressore
4	Motor ventilador 2	Motor ventilator 2	Motovenilatore2
5	Transformador	Transformer	Trasformatore
6			
7			
8	Fusible visualizador temp.	Electronic temp. visual display fuse	Fusibile visualizzatore di temperatura
9	Visualizador electrónico	Electronic temperature visual display	Visualizzatore di temperatura
10			
11	Interruptor palas izquierda	Left shovels switch	Interruttore coclea sinistra
12	Conmutador líquido/granizado izq.	Left liquid/iced drink switch	Deviatore bibita/granita vasca sinistra
13	Motor palas izquierda	Engine for left shovels	Motore coclea sinistra
14	Micro termostato izquierda	Left micro thermostat	Microinterruttore termostato sinistro
15	Micro regulación izquierda	Left micro regulation	Microinterruttore regolazione sinistro
16	Electroválvula izquierda	Left electrovalve	Elettrovalvola sinistra
17	Interruptor palas central	Central shovels switch	Interruttore coclea central
18	Conmutador líquido/granizado central	Central liquid/iced drink switch	Deviatore bibita/granita vasca central
19	Motor palas central	Engine for central shovels	Motore coclea central
20	Micro termostato central	Central micro thermostat	Microinterruttore termostato central
21	Micro regulación central	Central micro regulation	Microinterruttore regolazione dcentral
22	Electroválvula central	Central electrovalve	Elettrovalvola central
23	Interruptor palas derecha	Right shovels switch	Interruttore coclea destra
24	Conmutador líquido/granizado der.	Right liquid/iced drink switch	Deviatore bibita/granita vasca destra
25	Motor palas derecha	Engine for right shovels	Motore coclea destra
26	Micro termostato derecha	Right micro thermostat	Microinterruttore termostato destro
27	Micro regulación derecha	Right micro regulation	Microinterruttore regolazione destro
28	Electroválvula derecha	Right electrovalve	Elettrovalvola destra

